



# BATTERY VOLTAGE 4-20mA TRANSDUCER



The **Micha Battery Voltage to 4-20mA Transducer** (PN: 101920) has been designed for use in any application where a 4-20mA signal is required from a DC voltage source. The control circuitry is powered from the input and, as a loop-powered device, it requires a suitable current source to be connected to the output.

The module will operate from any voltage between 9 and 80VDC, with the on-board microcontroller allowing user-set offsets and ranges for maximum flexibility.

Two LED's give continuous status, a Blue LED indicating operating status and a Green LED shows current flowing through the output loop.

The transducer is housed in a plastic enclosure with integral clips for symmetric (35 x 7.5mm) and asymmetric (32 x 15mm) DIN rails.

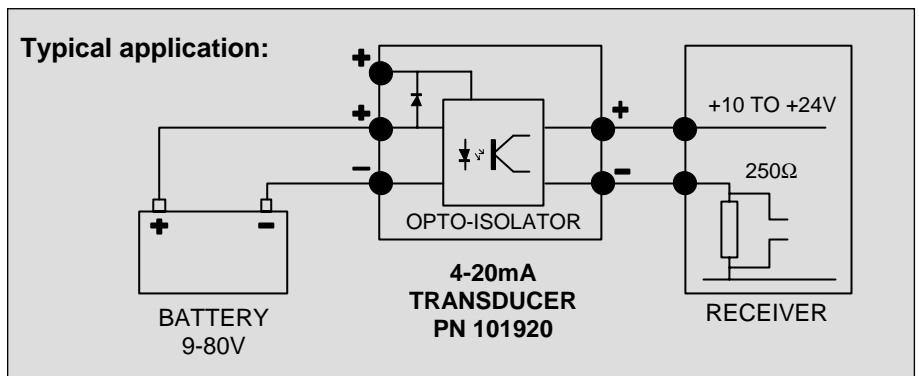

## Connections and Setup:

The voltage to be measured is connected to terminals 3 & 4. If a voltage of less than 9.0V is to be measured, a separate supply of between 8-80V must be connected to terminal 5.

**Note:** these supplies must have a common 0V.

The 4-20mA loop 'receiver' should source a voltage of between 10-24V which should be connected across the output terminals 1 & 2.

The voltage range of the unit is selected using DIP switches 7 & 8. For example, to use offsets and spans in the 24V range, set switch 7 to the '1' position (ON) and switch 8 to the '0' position (OFF).

**Note:** a switch is set to '1' when moved to the right (ON) position.

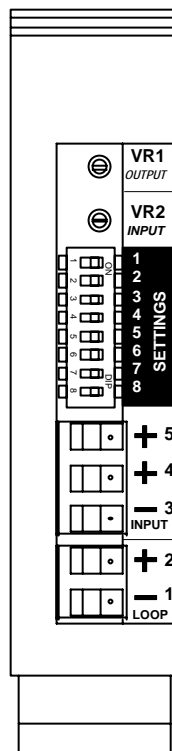

**Micha** www.micha.co.uk **0-80VDC to 4-20mA TRANSDUCER (LOOP-POWERED) PN: 101920**

**VR1 : Calibrate 20mA Output**  
REFER TO MANUAL FOR FULL USER INSTRUCTIONS.

**VR2 : Calibrate Input**

**STATUS LED**

1 x ● OK

2 x ● UNDER-RANGE

3 x ● OVER-RANGE

**DIP SWITCH SETTINGS:**

0 = OFF    1 = ON

**SET SWITCHES FOR REQUIRED SCALE:**

EXAMPLE: 01 10 00 10

12V = 4mA : 36V = 20mA : Normal mode

**SWITCHES 5 & 6:**

Set to xx xx 11 xx for fixed 20mA output for calibration.

<b>12 : 4mA (Offset)</b>							
	12V	24V	36V	48V			
00	0	0	0	0	0	0	0
01	6	12	18	24	30	36	42
10	8	16	24	32	40	48	56
11	10	20	30	40	50	60	70

<b>34 : 20mA (Span)</b>							
	12V	24V	36V	48V			
00	10	20	30	40	0	0	0
01	15	30	45	60	0	0	0
10	18	36	54	72	0	0	0
11	20	40	60	80	0	0	0

<b>56 : Mode</b>							
00	Normal						0
01	Ext: <3mA to 20mA						0
10	Fixed 4mA						0
11	Fixed 20mA						0

<b>78 : Range</b>							
00	48V						0
01	36V						0
10	24V						0
11	12V						0

INPUT RANGE: 9-80VDC - NOMINAL CURRENT: 4mA | LOOP VOLTAGE: 10-24VDC

Specification liable to change.

© The Micha Design Company Ltd. 2009

info@micha.co.uk

Issue 2: 29-Jan-2009

## Setting the Offset and Span:

The microprocessor allows the user to set a variety of offsets and spans, regardless of the input voltage. For example, if monitoring a 24V battery, the user can select the 4-20mA output to cover an input range of 20 to 30V.

**Offset:** Switches **1 & 2** set the offset (input voltage to give 4mA) depending on the voltage range selected with switches 7 & 8.

**Span:** Switches **3 & 4** set the span (input voltage to give 20mA) depending on the voltage range selected with switches 7 & 8.

**Example:** to set a range of 20-30V (20V = 4mA; 30V = 20mA), the switches should be set as follows:

Sw1: 1	Sw2: 1	Sw3: 0	Sw4: 1	Sw5: 0	Sw6: 0	Sw7: 1	Sw8: 0
Offset = 20V		Span = 30V		Mode = Normal		Input Range: 24V	

As the unit will operate on a voltage between 9 and 80V, it is permissible to set a voltage range that is more suitable to the output required.

**Example:** to set a range of 24 to 30V, the switches should be set as follows:

Sw1: 1	Sw2: 0	Sw3: 0	Sw4: 0	Sw5: 0	Sw6: 0	Sw7: 0	Sw8: 1
Offset = 24V		Span = 30V		Mode = Normal		Input Range: 36V	

## Selection Switches

**12 : 4mA (Offset)**

	12V	24V	36V	48V
00	0	0	0	0
01	6	12	18	24
10	8	16	24	32
11	10	20	30	40

**34 : 20mA (Span)**

	12V	24V	36V	48V
00	10	20	30	40
01	15	30	45	60
10	18	36	54	72
11	20	40	60	80

**56 : Mode**

00	Normal (4-20mA)
01	Ext: <3mA-20mA
10	Fixed 4mA
11	Fixed 20mA

**78 : Range**

00	48V
01	36V
10	24V
11	12V

**1 = ON    0 = OFF**

## Mode:

For normal use, switches 5 & 6 should be set to **0 0**. If the input voltage drops below the Offset value, the output will remain at 4mA. If switches 5 & 6 are set to **0 1**, the output can drop to approximately 3mA, which may be detected as a fault by the receiving transducer. Note: the maximum output is 20mA.

For uses of the fixed 4mA and 20mA modes, see the calibration section.

## Indicators:

During normal operation, the blue **STATUS** LED on the top of the unit will flash once approximately once a second. If the input voltage drops below the Offset voltage, the **STATUS** LED will blink twice, and if the input voltage exceeds the Span voltage, the **STATUS** LED will blink three times.

The **OUTPUT** LED is in series with the output loop and varies in intensity with the 4-20mA current.

## Calibration:

If it is necessary to re-calibrate to unit, this can be done as follows:

### Set DIP Switches 5 & 6 to 1 1.

Fit a 100R resistor in series with the output and connect a voltmeter (DVM) across it. Adjust VR1 until the DVM reads 2.00V (representing 20mA). The 4mA output can be confirmed by setting switches 5 & 6 to **1 0** and checking a voltage of 0.40V across the resistor.

### Set DIP Switches 5 & 6 to 0 0

With the Span set to the required voltage, apply that voltage to the input terminals (e.g. Switches 3&4 = **01**, 7&8 = **10**, Input = 30V). Adjust VR2 until the DVM just reads 2.00V. Note: if the input voltage exceeds the Span setting, the output will remain at the maximum of 20mA but the STATUS LED will flash three times.

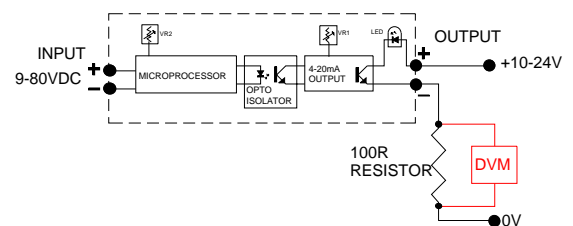

## General Specification:

- Supply Input Voltage Range : 9VDC to 80VDC at nominal 4mA (8VDC to 80VDC into terminal 5)
- Loop Voltage Range : 10VDC to 24VDC, maximum burden at 24V approx 560R
- Connectors : 2-part, rising-clamp, maximum cable size: 2.5mm<sup>2</sup>
- Accuracy/Linearity : Better than 1%
- Operating Temperature Range : -5°C to +55°C
- Enclosure : Self-extinguishing polyamide 6,8 (UL 94 v0)
- Dimensions : 22.5mm (W); 82mm plus terminals (D); 102mm above chassis
- Order code : 101920