

CPCx 25/50

CATHODIC PROTECTION CONTROLLER

PRODUCT MANUAL



1. Introduction

The CPCx range of impressed current cathodic protection controllers, although primarily designed for PV systems, is capable of operating with any stable DC power source. The units are available in two output current versions: 25A and 50A and in three input voltage versions: 12V, 24V and 48V. High speed pulse width modulated switching technology is utilised to obtain high conversion efficiency, thus minimising costs in the solar system providing the power.

The following table summaries the units that are available:

Unit	Output Current	Painted Steel Enclosure IP66	Stainless Steel Enclosure IP66	GRP (Polyester) Enclosure IP65	19" Rack Enclosure
CPCx25A	25.0A	600 x 400 x 210	600 x 400 x 210	645 x 435 x 250	4U High (177mm high)
CPCx50A	50.0A	600 x 400 x 210	600 x 400 x 210	645 x 435 x 250	8U High (355mm high)

1.1. Cathodic Protection Modes

The cathodic protection controller can operate in one of three modes, automatically switching between these when pre-set limits (user adjustable set-points via multi-turn potentiometers) are reached, as dictated by changing ground conditions. Each parameter is displayed on a digital LCD display:

Constant Voltage Control / Constant Current Control / Automatic Voltage Control (using feedback from a remote reference electrode that senses true structure to pipe potential – supplied by others)

1.2. Diagnostic facilities:

1.2.1. High Output Current Alarm (Relay 1)

Alarm which can be set to trip on a pre-set over current and indicated via illumination of an LED and activation of a relay (with one set of potential free changeover contacts available to the user).

1.2.2. Low Output Current Alarm (Relay 2)

Alarm which can be set to trip on a pre-set low current and indicated via illumination of an LED and activation of a relay (with one set of potential free changeover contacts available to the user).

1.2.3. Low Input Voltage Alarm (Relay 3)

Alarm which can be set to trip on a pre-set low input voltage and indicated via illumination of an LED and activation of a relay (with one set of potential free changeover contacts available to the user).

1.2.4. Interrupt Timer

A function to interrupt the output current. The ON / OFF periods are independently adjustable from 1 to 9999 seconds.

1.3. Major Components

1.3.1. CPCx Control PCB Assembly

The main functions of the CP Controller are contained on a single PCB assembly. These include:

Parameter measurement, control by microprocessor, analogue modulation control, control power supply, interrupt timer function, alarm functions

1.3.2. CPCx Power PCB Assembly

The power switching elements are separated from the main control and designed as modular units.

1.4. Limitations of Use

1.4.1. Although the Cathodic Protection Controller should not be damaged by connection to a short circuit, the output waveform ceases to be smooth DC and meter readings may be inaccurate. The minimum recommended load resistance is 0.25Ω.

2. Health and Safety

2.1. General

Read this manual thoroughly BEFORE undertaking any work.

Potentially lethal voltages can be present at the terminals within the Controller. Capacitors, used in the smoothing circuits, can retain energy long after the unit has been isolated. Extreme care MUST be taken when performing any of the actions described in this manual.

Remove all metallic personal adornments from the hands, wrists and neck before commencing work on a live unit.

Ensure all tools are insulated.

Whenever a cable has to be disconnected it should be insulated with insulating tape and labelled to ensure correct reconnection.

2.2. Earthing

The cathodic protection controller is part of a common positive system. Any charge controller connected to the input of the Cathodic protection controller must also be common positive.

The mounting plate and enclosure have not been linked to the common positive to prevent corrosion and must be separately earthed to provide lightning protection.

Recommended System Wiring for Cathodic Protection Systems

As a CP system works by passing current through 'ground', it is essential that the system Common - the Positive Rail - is only grounded at the output of the CP Controller. If a ground connection is made at any other point in the system, it is possible that the CP Controller will not be able to monitor or control the output current and voltage correctly, particularly if a reference electrode is used.

Grounding of Enclosures

The grounding of enclosures and structures is acceptable, but under no circumstances should a connection be made from the system common to a metal enclosure or structure otherwise the protective current is liable to have an adverse effect on these parts, and in some cases may accelerate corrosion.

3. Installation

3.1. Mounting and Position

The Cathodic Protection Controller should be installed using the four mounting feet provided and situated within 2 meters of the Charge Controller. Ensure that the fixing method employed is sturdy enough to support the weight of the unit. Position the unit so that it is shaded from direct sunlight, sheltered from extreme weather conditions and oriented so that the cable glands are pointing downwards.

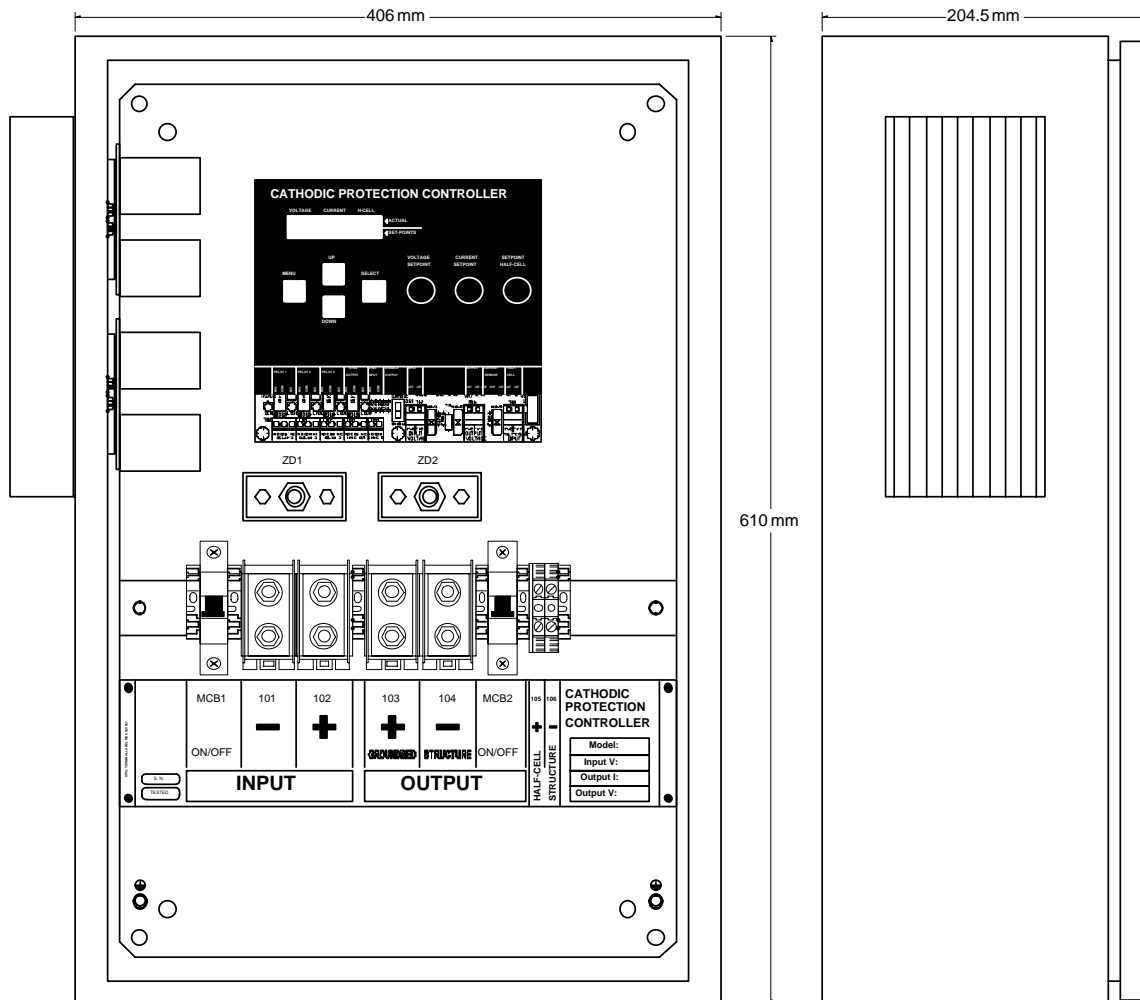

3.2. Electrical Connections

The electrical connections can be made to the Cathodic Protection Controller once the Charge Controller has been installed and commissioned. Before proceeding with any electrical connections, first ensure that the output MCB of the Charge Controller (if it has one) is in the OFF position.

- 3.2.1. Ensure the ENABLE / DISABLE control on the CPCx Control PCB Assembly is in the DISABLE position
- 3.2.2. CPCx Unit terminal INPUT +VE connect to the Charge Controller terminal LOAD +VE (Common)
- 3.2.3. CPCx Unit terminal INPUT -VE connect to the Charge Controller terminal LOAD -VE
- 3.2.4. CPCx Unit terminal OUTPUT +VE connect to the Groundbed
- 3.2.5. CPCx Unit terminal OUTPUT -VE connect to the Structure to be protected
- 3.2.6. CPCx Unit terminal HALF-CELL +VE connect to the Half-cell (if being used)
- 3.2.7. CPCx Unit terminal HALF-CELL -VE connect to the Structure to be protected (if being used)
- 3.2.8. CPCx Unit Alarm Relay Contacts: connect to external telemetry system as required

3.3. Reference Electrode (Half-Cell)

3.3.1. The Reference Electrode is also referred to in this manual as the Half-Cell. A diagram of how a Half-Cell should be connected is shown below. Note that for protection of the structure, the potential of the structure should be at a lower potential than the Groundbed. Although this may be considered a negative voltage, only the value of the Half-Cell voltage is shown on the display; i.e. if the connections have been made as shown below then the Structure connection to the Half-Cell input will be more negative than the Positive connection to the Half-Cell, and the value of that potential will be shown on the display.

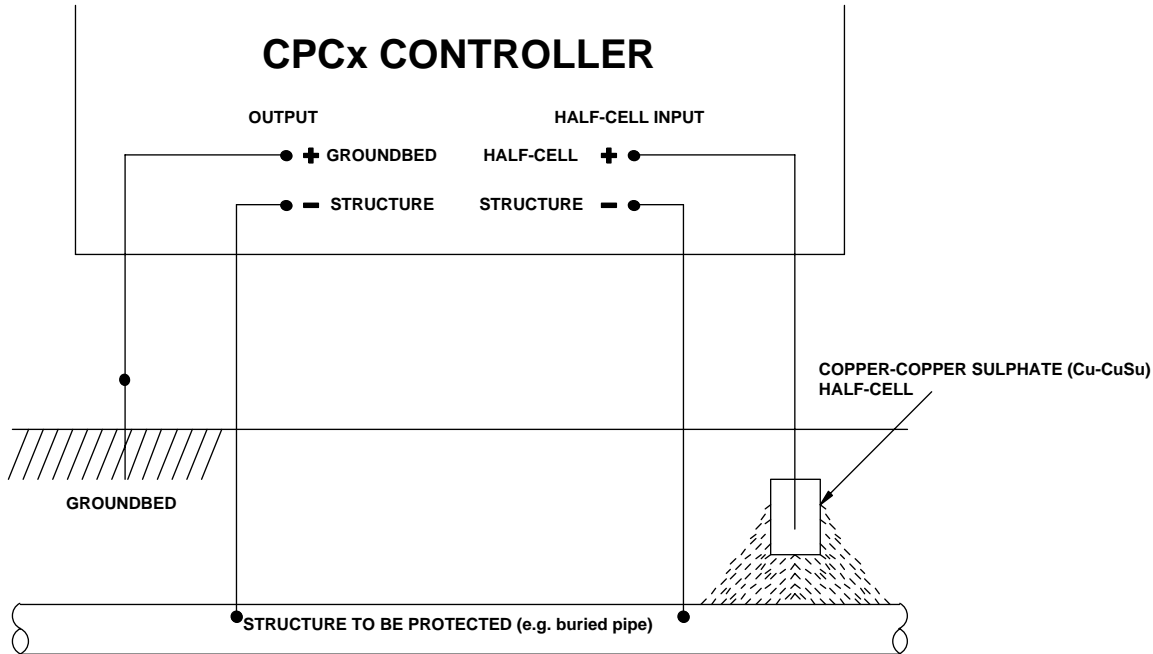

Recommended System Wiring for Cathodic Protection Systems

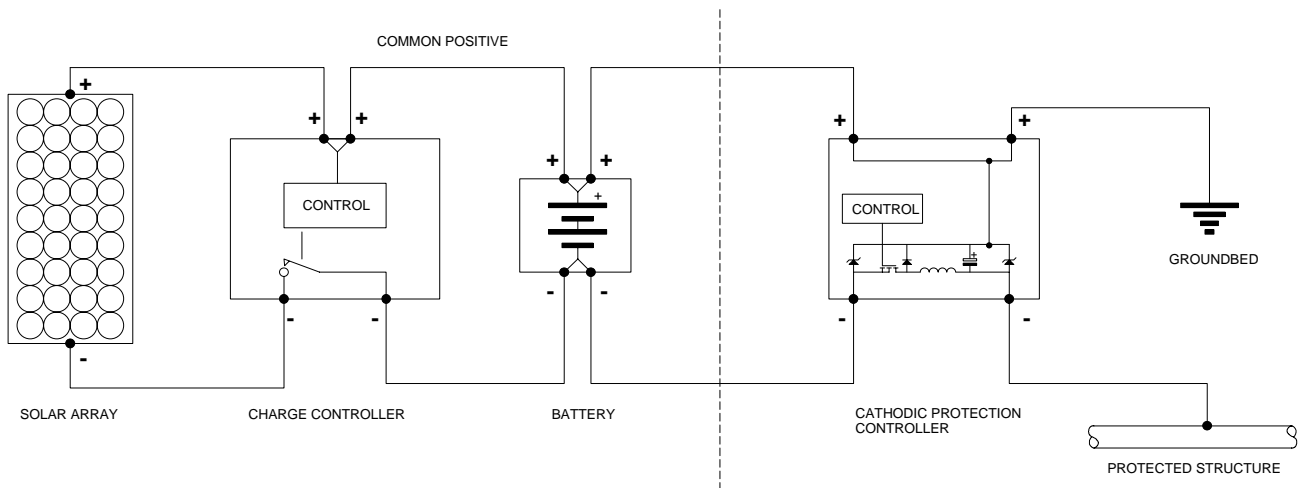

As a CP system works by passing current through ‘ground’, it is essential that the system Common - the Positive Rail - is only grounded at the output of the CP Controller. If a ground connection is made at any other point in the system, it is possible that the CP Controller will not be able to monitor or control the output current and voltage correctly, particularly if a reference electrode is used.

Grounding of Enclosures

The grounding of enclosures and structures is acceptable, but under no circumstances should a connection be made from the system common to a metal enclosure or structure otherwise the protective current is liable to have an adverse effect on these parts, and in some cases may accelerate corrosion.

4. Operation

4.1. Operational Menus

The Cathodic Protection Controller uses a microprocessor to provide control and diagnostic features in the unit. A 2x16 alphanumeric LCD Display is used to indicate parameters and set-points as described below. The following diagram describes the various screens available to the user:

CPCx Software Menu Guide:

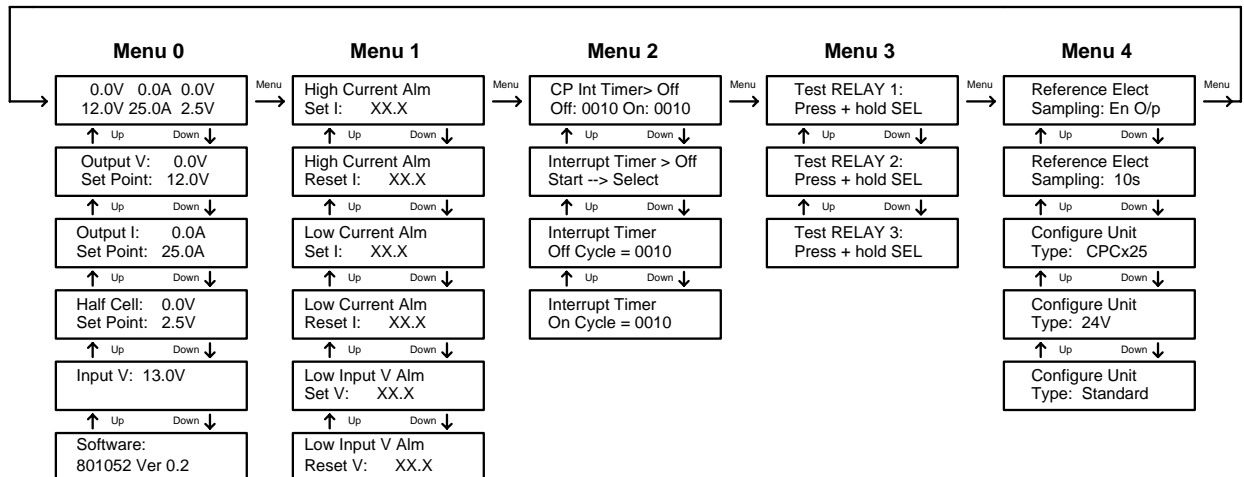

Navigating the menus is done by using the Menu, Up and Down switches while the Select switch will activate various functions.

Pressing the Menu switch at any screen in Menu 0 will change the display to show the top screen of Menu 1. In a similar manner, the user can move to Menu 2, 3 and 4 and back to Menu 0, by pressing the Menu switch repeatedly.

The Up and Down Switches will move the user up and down within a menu.

4.1.1. Menu 0

This is the default and start-up menu which displays the actual and set-point values for the three parameters: output voltage, output current, reference electrode (half-cell) voltage.

These parameters can be displayed on separate screens or all on the one screen.

The Input Voltage is also available and the Software Number and Version.

4.1.2. Menu 1

Menu 1 is the High Output Current, Low Output Current and Low Input Voltage Alarm Set-points menu – see sections 4.12 to 4.14 for a description of the setting of the alarms.

4.1.3. Menu 2

Menu 2 is the Interrupt Timer Control menu – see section 4.9 for a description of the operation of the Interrupt Timer.

4.1.4. Menu 3

Menu 3 is the Alarm Relay Test menu – see sections 4.12 to 4.14 for a description of the function of Relays 1-3.

4.1.5. Menu 4

Menu 4 is the Unit Configuration menu – see section 4.18.

4.2. Preliminary Checks

Before applying power to the Cathodic Protection Controller (i.e. by switching the Charge Controller output MCB on) ensure that:

- all three CP control potentiometers are fully counter clockwise
- the CP output MCB is set to its OFF position
- the CP Enable/Disable switch is set to the Enable position

4.3. Applying Power

Set the Charge Controller output MCB to its ON position.

Using a meter set on the 200VDC range, check that a voltage of approximately 12, 24 or 48V of the correct polarity is present across the INPUT +VE and -VE terminals of the Cathodic Protection Controller.

Ensure the green Status LED (located in the lower left hand corner of the CPCx Control PCB Assembly) is illuminated.

4.4. Output MCB ON

Switch the Cathodic Protection Controller output circuit breaker to its ON position and verify the LCD display indicates the following ± 0.3 (assuming there is no half-cell fitted):

Voltage	Current	H-Cell	
00.0V	00.0A	0.0V	Actual
00.0V	00.0A	0.0V	Set-Points

Note: If a Reference Electrode is fitted, the indication on the reference electrode meter should match the structure to soil potential (as measured by a portable reference electrode and meter).

Note: If a Reference Electrode is not fitted, then turn the Reference Electrode Set-point control fully clockwise to ensure this cannot interfere with normal operation. Also, ensure a wire link is fitted across the Half-Cell input terminals.

4.5. LED Indication at Start Up

With no output current flowing, and the interrupt timer not active, the LED indication should be as follows:

Parameter	Indicator	Status
High Output Current	Relay 1 & LED	Extinguished
Low Output Current	Relay 2 & LED	Illuminated (I < 1A) / Extinguished (I > 3A)
Low Input Voltage	Relay 3 & LED	Depends on Input Voltage and Set-points
Timer On	Sync Out Relay & LED	Extinguished

4.6. Constant Voltage Control

The Cathodic Protection Controller can now be set up to operate at the required level in the appropriate operating mode.

To ensure that automatic half-cell control does not interfere with this, turn the REFERENCE ELECTRODE (HALF-CELL) SET-POINT control fully clockwise.

Ensure that the VOLTAGE SET-POINT control is in the fully counter clockwise position.

Product Manual

Turn the CURRENT SET-POINT control in a clockwise direction until the required output current (e.g. 10 Amps) is indicated on the meter (Note: the voltage and current actual values should continue to be zero):

Voltage	Current	H-Cell	
00.0V	00.0A	0.0V	Actual
00.0V	10.0A	4.0V	Set-Points

Adjust the VOLTAGE SET-POINT control in a clockwise direction. The voltage and current actual values should indicate an increase as the control is rotated. The CP Controller is operating in Constant Voltage Mode (readings dependant on ground conditions – example shown is 0.75Ω):

Voltage	Current	H-Cell	
06.0V	08.0A	0.0V	Actual
06.0V	10.0A	4.0V	Set-Points

4.7. Constant Current Control

Continue to increase the VOLTAGE SET-POINT control until the voltage and current actual values indicate no further increase. The current actual value should equal the current set-point value (e.g. 10A). The CP Controller is operating in Constant Current Mode (readings dependant on ground conditions – example shown is 0.75Ω):

Voltage	Current	H-Cell	
07.5V	10.0A	0.0V	Actual
16.0V	10.0A	4.0V	Set-Points

4.8. Automatic Reference Electrode (Half-Cell) Voltage Control

This is only applicable if there is a Reference Electrode (Half-Cell) for automatic control.

With the unit operating in the Constant Current Control Mode, adjust the HALF-CELL SETPOINT control counter clockwise until the half-cell voltage set-point indicates the required pipe-soil potential, e.g. 1V.

After some time (depending on ground conditions) the CP System will begin to polarise. To speed up the process, leave the unit operating in Constant Current Mode until the required structure to soil potential is achieved. As the structure potential increases towards the HALF-CELL SETPOINT the CP output current will reduce and the Cathodic protection controller will then be working in Automatic Half-Cell Control Mode (readings dependant on ground conditions – example shown is 0.75Ω):

Voltage	Current	H-Cell	
07.5V	10.0A	1.0V	Actual
26.0V	20.0A	1.0V	Set-Points

The Reference Electrode (Half-Cell) is connected to its sensing circuit by solid state switches. This means that the Reference Electrode is normally disconnected electrically from the unit and is only connected briefly to enable a measurement to be taken and this value is stored and used for control between samples. Before the Reference Electrode is sampled, the CP output can be disabled momentarily. If no Reference Electrode is used, it is recommended that sampling is disabled - i.e. the CP Output is set to Enabled - see section 4.18 The sampling period may be changed by the user to a period between 10 and 240 seconds.

It is normal operation for the SYNC OUT Relay and LED to activate briefly as the CP Output is disabled while the Reference Electrode is being sampled.

4.9. Interrupt Timer

Set the Cathodic Protection Controller to run in the desired operating mode as described above.

Navigate to the Interrupt Timer Menu (Menu 2).

4.9.1. Changing the Interrupt Timer Off Cycle Time

Navigate (using the Up and Down switches) to the Interrupt Timer Off Cycle screen.

Use the Select switch to select each digit in turn in order to change its value. Use the Up and Down switches to change the flashing digit. After all four digits have been selected in turn, press Select to accept the new value. No digit will flash and the new value is accepted.

4.9.2. Changing the Interrupt Timer On Cycle Time

Navigate (using the Up and Down switches) to the Interrupt Timer On Cycle screen.

Use the Select switch to select each digit in turn in order to change its value. Use the Up and Down switches to change the flashing digit. After all four digits have been selected in turn, press Select to accept the new value. No digit will flash and the new value is accepted.

4.9.3. Activating the Interrupt Timer

Navigate (using the Up and Down switches) to the Interrupt Timer Start screen.

Press the Select switch to activate the interrupt timer.

When the timer is activated the CP output will be disabled for the Off Cycle Time and the enabled for the On Cycle Time repeatedly until the timer is de-activated.

When the CP output is disabled, the SYNC OUT LED will be illuminated and the relay activated.

4.9.4. De-activating the Interrupt Timer

Navigate (using the Up and Down switches) to the Interrupt Timer Stop screen.

Press the Select switch to de-activate the interrupt timer.

The CP Output will return to the normal operation as set before the timer was activated.

4.10. External Interrupt Timer

It is possible to use an external interrupt timer with the CP Controller.

The external interrupt timer should have a volt-free set of contacts to connect to the terminals SYNC IN on the CPCx Control PCB Assembly. When these contacts are closed, the CP output will be disabled. When these contacts are open, the CP output will be enabled.

This option can be used instead of the on-board interrupt timer.

4.11. Synchronise Input / Output

The unit has a synchronise input (SYNC IN) which interrupts the output current when this input is active. To make the input active, an independent volt-free contact should be used to connect the NO to the COM of the SYNC IN input.

The unit has a synchronise output (SYNC OUT) which is active only during the interrupt timer programmable OFF period. This output is a volt-free changeover relay contact.

By connecting the SYNC OUT (N/O and COM contacts) of one unit to the SYNC IN of another unit, the interrupt timer of one unit can be used to synchronise the current interruption of another unit.

Alternatively, the user can supply their own synchronised clocks and connect them to the SYNC IN terminals to enable a synchronised interruption of current across a series of controllers which may be a distance apart.

4.12. High Output Current Alarm

The Cathodic Protection Controller has a High Current Alarm function. If the CP output current exceeds the trip value then Relay 1 will activate and the associated LED will illuminate. If the CP output current falls below the reset value then Relay 1 will de-activate and the associated LED will extinguish. The action of Relay 1 may be tested using Menu 3.

4.12.1. Setting the High Current Alarm Trip Set-point

It is not possible to set the High Current Alarm Trip set-point less than the High Current Alarm Reset set-point. For this reason, if a reduction in value is required, set the reset set-point first.

Navigate to the High Current Alarm Set screen in Menu 1.

Press the Select switch and the value will flash. Use the Up and Down switches to adjust the value. Press the Select switch to accept the new value.

4.12.2. Setting the High Current Alarm Reset Set-point

It is not possible to set the High Current Alarm Reset set-point greater than the High Current Alarm Trip set-point. For this reason, if an increase in value is required, set the trip set-point first.

Navigate to the High Current Alarm Reset screen in Menu 1.

Press the Select switch and the value will flash. Use the Up and Down switches to adjust the value. Press the Select switch to accept the new value.

4.13. Low Output Current Alarm

The Cathodic Protection Controller has a Low Current Alarm function. If the CP output current falls below the trip value then Relay 2 will activate and the associated LED will illuminate. If the CP output current exceeds the reset value then Relay 2 will de-activate and the associated LED will extinguish. The action of Relay 2 may be tested using Menu 3.

4.13.1. Setting the Low Current Alarm Trip Set-point

It is not possible to set the Low Current Alarm Trip set-point greater than the Low Current Alarm Reset set-point. For this reason, if an increase in value is required, set the reset set-point first.

Navigate to the Low Current Alarm Set screen in Menu 1.

Press the Select switch and the value will flash. Use the Up and Down switches to adjust the value. Press the Select switch to accept the new value.

4.13.2. Setting the Low Current Alarm Reset Set-point

It is not possible to set the Low Current Alarm Reset set-point less than the Low Current Alarm Trip set-point. For this reason, if a reduction in value is required, set the trip set-point first.

Navigate to the Low Current Alarm Reset screen in Menu 1.

Press the Select switch and the value will flash. Use the Up and Down switches to adjust the value. Press the Select switch to accept the new value.

4.14. Low Input Voltage Alarm

The Cathodic Protection Controller has a Low Input Voltage Alarm function. If the input voltage falls below the trip value then Relay 3 will activate and the associated LED will illuminate. If the input voltage exceeds the reset value then Relay 3 will de-activate and the associated LED will extinguish. The action of Relay 3 may be tested using Menu 3.

4.14.1. Setting the Low Input Voltage Alarm Trip Set-point

It is not possible to set the Low Input Voltage Alarm Trip set-point greater than the Low Input Voltage Alarm Reset set-point. For this reason, if an increase in value is required, set the reset set-point first.

Navigate to the Low Input Voltage Alarm Set screen in Menu 1.

Press the Select switch and the value will flash. Use the Up and Down switches to adjust the value. Press the Select switch to accept the new value.

4.14.2. Setting the Low Input Voltage Alarm Reset Set-point

Product Manual

It is not possible to set the Low Input Voltage Alarm Reset set-point less than the Low Input Voltage Alarm Trip set-point. For this reason, if a reduction in value is required, set the trip set-point first.

Navigate to the Low Input Voltage Alarm Reset screen in Menu 1.

Press the Select switch and the value will flash. Use the Up and Down switches to adjust the value. Press the Select switch to accept the new value.

4.15. Manual Disable Switch

An Output Disable switch is provided on the CPCx Control PCB Assembly which allows the user to disable (i.e. interrupt) the output current as required by moving the switch to the Disable position. For normal operation it should be in the Enable position.

4.16. Optional 4-20mA Outputs

An optional CPCx 3-Channel 4-20mA Transducer PCB Assembly may be supplied which will convert the Output Voltage, Output Current and Reference Electrode Potential to 4-20mA signals.

Output Voltage 0-50V => 4-20mA

Output Current 0-50A => 4-20mA

Reference Electrode 0-5V => 4-20mA

The 4-20mA signals are isolated from each other and from the CPCx.

The 4-20mA signals are loop-powered; i.e. they modulate the current passing through the output circuit, but the power for the 4-20mA signal must be supplied by the device to which they are connected.

4.17. RS232 Communications

The CPCx PCB Assembly includes an RS232 Port and Data Logging facility. The RS232 port is terminated on PCB terminals (TB6 on the top edge of the PCB). A Din Rail Connection PCB Assembly is available to allow connection to a standard 9-way D-type connector (MDC 401097). Software is available for a PC to communicate and download information about the CPCx status.

In order to save power in an application where an RS232 port is not required, the power to the RS232 port may be removed by removing LK6 and any wire link across TB15 terminals. To provide power to the RS232 port, either insert a jumper link on LK6 or insert a wire link across TB15 terminals.

4.18. Menu 4 – Configuration Menu

Display	Screen	Description
Reference Elect Sampling: En O/p	Screen 0	Reference Electrode (Half-Cell) Sampling – when the measurement is made the user can choose to Enable the CP Output (default) or Disable the CP Output.
Reference Elect Sampling: 10s	Screen 1	Reference Electrode (Half-Cell) Sampling – the user can vary the time between sampling of the Reference Electrode (Half-Cell) (Default = 10 seconds).
Configure Unit: Type: CPCx25	Screen 2	The unit is configured in the factory as a CPCx25A or CPCx50A unit.
Configure Unit: Type: 24V	Screen 3	The unit is configured in the factory as a 12V, 24V or 48V unit.
Configure Unit: Type: Standard	Screen 4	The unit is configured in the factory as a Standard or 19” Rack unit.

4.18.1. Reference Electrode (Half-Cell) Sampling

Some Reference Electrodes (Half-Cells) require to be connected to electronics with an extremely high input impedance – typically 20M Ohms. It can be a major challenge to design a measurement circuit which will satisfy this requirement over years and in a hot and humid environment.

The CPCx unit meets this requirement by using a high impedance measurement circuit which is only connected to the Half-Cell for a short period of time (typically milliseconds) and then is disconnected from the Half-Cell for most of the time: i.e. the CPCx samples the value every X seconds. The CPCx uses solid-state switching devices to sample the Half-Cell.

The user can use Menu 4 Screen 0 to enable and disable disconnection of the output during sampling, and Screen 1 to vary the Sampling time from 1 to 240 seconds.

5. Installation of PCB Assemblies

The following instructions should be carried out when installing/replacing any of the PCB Assemblies

5.1. CPCx Control PCB Assembly

- 5.1.1. Ensure the output MCB is in its OFF position.
- 5.1.2. Isolate the input power (usually at the charge controller) to ensure no power is connected to the unit.
- 5.1.3. Remove the fascia over the CPCx Control PCB Assembly by loosening the four plastic screws.
- 5.1.4. Disconnect the connections to the CPCx Power PCB Assemblies by removing the connectors from TB3 and TB5 (CPCx50 only) on the left hand side of the PCB Assembly beside the LCD Display.
- 5.1.5. Remove the wires to the terminal blocks on the bottom edge of the PCB Assembly and mark each wire for reconnection.
- 5.1.6. Remove the PCB Assembly fixings and install the new CPCx Control PCB Assembly.
- 5.1.7. Reconnect the wires to the correct terminal blocks on the bottom edge of the PCB Assembly.
- 5.1.8. Reconnect the connections to the CPCx Power PCB Assemblies by installing the connectors from TB3 and TB5 (CPCx50) on the left hand side of the PCB Assembly beside the LCD Display.
- 5.1.9. Reconnect the power to the unit.
- 5.1.10. IMPORTANT:**

Ensure VR6 is adjusted fully clockwise. Adjust VR2 so that the maximum Output Current Set-point displayed on the LCD Display is: 25.0A for a CPCx25A unit / 50.0A for a CPCx50A unit.
- 5.1.11. Replace the fascia over the CPCx Control PCB Assembly using the four plastic screws.
- 5.1.12. Reconnect the load by switching the output MCB to its ON position.

6. Maintenance

The following maintenance schedule should be undertaken annually.

6.1. Equipment Required

- 1 x Digital Multimeter (DMM) complete with test probes
- 1 x Enclosure touch up paint (if required).
- 1 x Flathead screwdriver (5mm).
- 1 x Flathead screwdriver (3mm).
- 1 x small soft brush.

6.2. Procedure

- 6.2.1. Check the enclosure for flaws in the paint finish (if appropriate). Touch up any defects with appropriate touch up paint.
- 6.2.2. Ensure that the door gasket has not been attacked by pests resulting in a loss of weatherproofing.
- 6.2.3. Check all external cables for any signs of damage or deterioration of the outer sheath. Verify that cables are adequately secured and that all cable glands give a weatherproof seal.
- 6.2.4. Ensure that all the terminals in the CPCx are free from corrosion and that all terminals are tight.
- 6.2.5. Verify the correct operation of the CPCx as described in Section 3.2.8 above.
- 6.2.6. Clean any small particles (e.g. sand, dust) from the enclosure using a small soft brush.
- 6.2.7. Ensure that the enclosure is shaded from direct sunlight and weathering at all times.

7. Software

7.1. Software History

Software Version	Date Released	Product Manual	Comments
801 052 Ver 1.1	22-Mar-2005	800 981 Issue 1	Software for Control PCB Assembly 400960 Issue 3
801 052 Ver 1.2	19-June-2006	800 981 Issue 2	Added Reference Electrode Sampling Selection (Enable or Disable Output during Reference Electrode measurement) – Menu 4 Screen 0 Added smoothing to the measurement of analogue values.

7.2. Installation / Replacement of the MCU

Ensure that anti-static precautions are taken to avoid damage to the Micro-controller when handling (i.e. touch a conductor that is connected to earth before carrying out the following):

Turn off all power to the CPCx Controller by turning off the output MCB of the connected charge controller.

Remove the CPCx Control PCB Fascia Cover using the four plastic thumbscrews. Identify IC14 (40 pin integrated circuit) on the PCB Assembly. Carefully lever out any Microcontroller presently located there by using a small flat screwdriver on both ends equally. Do this carefully.

Identify the device to be installed. Carefully handle the device without touching the legs of the device. NOTE the orientation of the semi-circular notch out of one end of the device. NOTE which end of IC14 has a notch in the PCB socket. Now insert the Microcontroller into the IC14 socket so that the notch in the device is at the same end as the notch in the socket. Before pressing down on the device to mate it fully in its socket, check that all pins are properly lined up with the pins in the PCB socket. Press the device fully into the socket and check that no leg has been bent or missed its socket.

Replace the CPCx Control PCB Fascia Cover using the four plastic thumbscrews.

Restore power to the CPCx Controller by turning on the output MCB of the connected charge controller.